

Experiment P007: Acceleration due to Gravity (Free Fall Adapter)

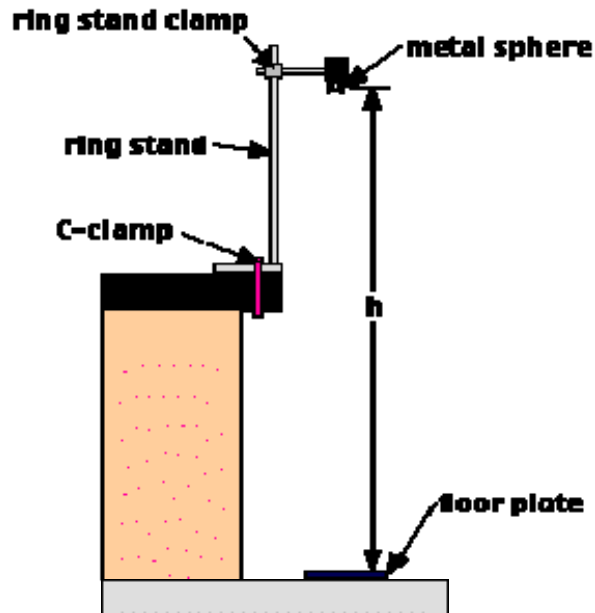

EQUIPMENT NEEDED

Science Workshop™ Interface
Clamp, right angle
Base and support rod
Free fall adapter
Balls, 13 mm and 19 mm
Meter stick (or metric tape measure)

PURPOSE

The purpose of this laboratory activity is to measure the acceleration of a falling object assuming that the only force acting on the object is the gravitational force.

THEORY

One equation describing the motion of a body starting from rest and undergoing constant acceleration can be expressed as:

$$d = \frac{1}{2}at^2$$

where **d** is the distance the object has traveled from its starting point, **a** is the acceleration of the object, and **t** is the time elapsed since the motion began.

Therefore, the acceleration is equal to the distance doubled, divided by the time squared, or:

$$a=2d/t^2$$

In order to measure the acceleration caused by the gravitational force, several questions must be answered:

Is the acceleration constant? If it is, then the distance the object falls will be proportional to the square of the elapsed time, as in the above equation.

If the acceleration is constant, what is the value of the acceleration? Is it the same for all objects or does it vary with mass, size, or with some other property of the object? If it is not constant, how does it vary with time?

PROCEDURE

For this laboratory activity, the free fall adapter will measure the time of fall for steel balls of different sizes and mass. Using a meter stick, you will directly measure the height the ball falls. The *DataStudio* program will then plot distance doubled vs. the time squared. Then the slope of the (best fit line) for this graph will then give the acceleration due to gravity, g.

PART I: Computer Setup

1. Open the *DataStudio* document titled as shown:

Windows: P007_ADAP.DS

The document will open with a Graph display of Distance “(m)” versus “Time (sec)”, and a Table display of “Free Fall Data”, the time of fall.

The Experimental Setup window has been resized. If you want to expand the Experiment Setup window to its original size, click on the “Zoom” box in the upper right hand corner of the window. (Note: To bring a display to the top, click on its window or select the name of the display from the list at the end of the Display menu.)

PART II: Sensor Calibration and Equipment Setup

You do not need to calibrate the free fall adapter.

1. Attach the right angle clamp to a vertical support rod. Mount the free fall adapter's release mechanism horizontally in the clamp.
2. Place the free fall adapter's timing pad on the floor directly below the release mechanism.
3. Place the larger ball (19 mm) in the release mechanism. Press the spring-loaded rod inward to hold the ball in the mechanism, and tighten the thumbscrew to hold the rod in place.
4. Adjust the position of the release mechanism so the bottom of the ball is approximately 1.75 meters above the timing pad.
5. Practice dropping the ball a few times before taking data.

PART IIIA: Data Recording – 19 mm Ball

1. Measure the height from the bottom of the ball to the top of the timing pad. Record this height in the Data table.
2. Click the “Start” button to begin data recording.
3. Loosen the thumbscrew to release the ball.
4. After the ball hits the timing pad, click “Keep”. Record your height and time.
5. Once again place the ball in the release mechanism. Adjust the position of the release mechanism so the bottom of the ball is 1.70 meters above the timing pad. Measure the height between the ball and the pad and record it in the Free Fall Data Table.
6. When you are ready to record the next drop, loosen the thumbscrew to release the ball.
7. After the ball hits the pad, click “Keep”. Record the height and time in the data table below.
8. Replace the ball in the mechanism. Move the mechanism so the bottom of the ball is approximately 1.65 meters from the top of the timing pad. Measure and record the height.
9. Loosen the thumbscrew to release the ball.

10. After the ball hits the timing pad record your height and time in the table below.
11. Repeat the process for heights of approximately 1.60 and 1.55 meters.
12. Click “Stop” at the end of all runs.

DATA TABLE: 19 mm Ball

Trial	Height (m)	Time (sec)
1		
2		
3		
4		
5		

Acceleration due to gravity (slope) $g =$

% Difference =

Reminder: percent difference = $\frac{|\text{accepted value} - \text{experimental value}|}{|\text{accepted value}|} * 100$

PART IIIB: Data Recording – 13 mm Ball

1. Place the smaller ball (13 mm) in the release mechanism. Adjust the position of the release mechanism so the bottom of the ball is 1.50 meters above the timing pad. Measure the distance from the bottom of the 13 mm ball to the top of the timing pad. Record this height in Data table.
2. Click the “START” button to begin data recording.
3. Loosen the thumbscrew to release the ball.
4. After the ball hits the timing pad. Click “Keep” and record your height and time in the table below.
5. Repeat the data recording process with the 13 mm ball for heights of 1.25, 1.00, 0.75, and 0.50 meters as in Part IIIA.

DATA TABLE: 13 mm Ball

Trial	Height (m)	Time (sec)
1		
2		
3		
4		
5		

Acceleration due to gravity (slope) $g =$

% Difference =

